

CARRELLINO 3



Possibile variante di utilizzo con l'accessorio del piano inox pasticceria o piatti pronti

- Eventual variant by using the accessory inox top for pastry or ready to serve dish
- Possible variante d'utilisation avec l'accessoire du plateau inox pour pâtisserie ou pour plats cuisinés
- Eventuelle Aenderung der Benutzung mit dem Zubehör von Inox Top für Konditorei oder fertige Speisen
- Posible variante de empleo con el accesorio del plano inoxidable pastería o platos listos.

Colori standard <i>Standard colors</i>			Colori optional <i>Optional colors</i>	
COD. 04	COD. 05	COD. 07	RAL	COD. 07T

Carrellino 3	+4/+10	mm. (LxPxH) 1170x675x1110	h. max. 100 mm. Gastronorm 1/1-2/3-1/2-1/3	290			230v/1/50Hz	R134a	79	-	-

Dati di collaudo • Test details • Détails d'essai • Prüfungsergebnisse • Datos de ensayo • MAX = (30°C - % U.R. 55)

Prezzi vedi LISTINO a pagina 94
See PRICE LIST on page 94



CARRELLINO 3

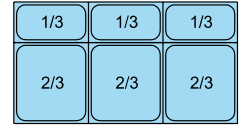
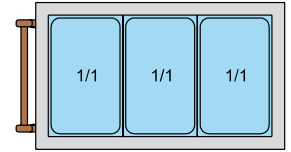
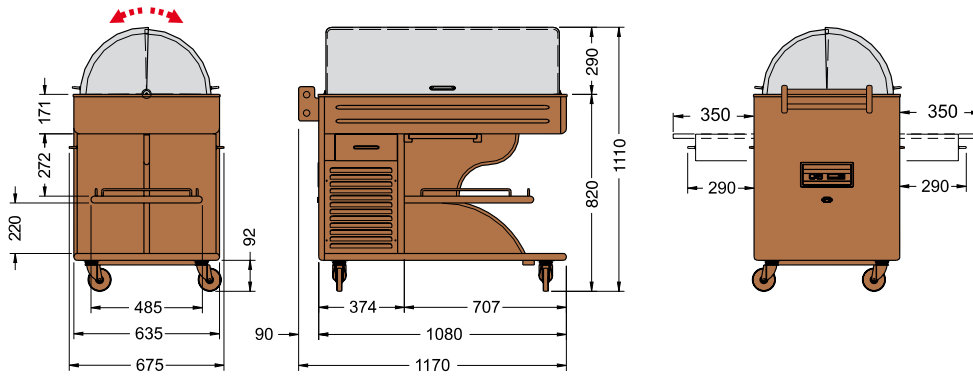

CARRELLINO 3 (Pasticceria)

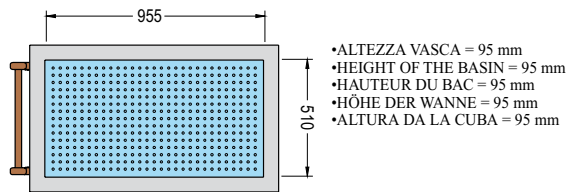

- LE VASCHE SONO FORNITE A RICHIESTA.
- BASINS ARE AVAILABLE ON REQUEST.
- LES BACS SONT FOURNIS SUR DEMANDE.
- DIE SCHALEN WERDEN AUF WUNSCH GELIEFERT.
- LAS CUBETAS SE ENTREGAN BAJO DEMANDA.

- ALTEZZA VASCA = 95 mm
- HEIGHT OF THE BASIN = 95 mm
- HAUTEUR DU BAC = 95 mm
- HÖHE DER WANNE = 95 mm
- ALTURA DA LA CUBA = 95 mm

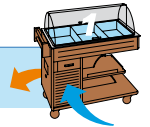

CARRETTINO 250

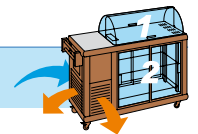
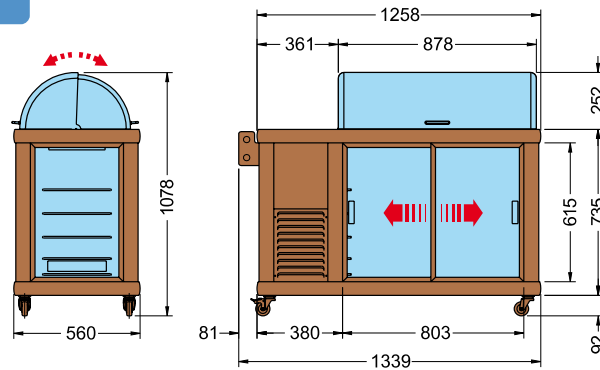

CARRELLINO EIS

