

# SELF-BREAKFAST SELF-BREAKFAST

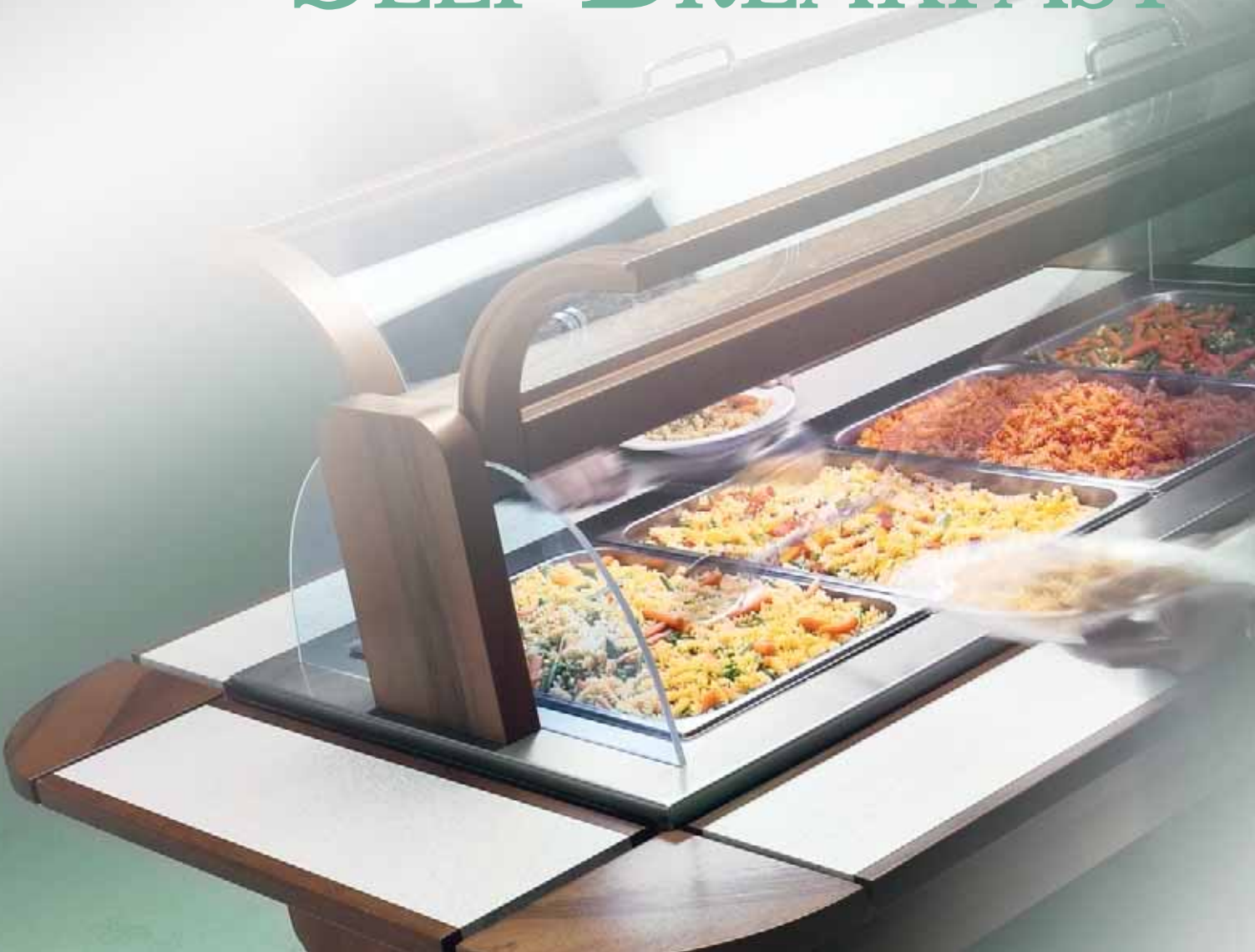

**EMAINOX**  
PROFESSIONAL FURNISHING SYSTEMS





**UNA LINEA COMPLETA E MULTIFUNZIONALE PER L'ESPOSIZIONE ED IL SERVIZIO DI CIBI E BEVANDE**

---

**EINE VOLLSTÄNDIGE UND VIELSEITIGE PALETTE ZUR BEDIENUNG UND AUSSTELLUNG VON SPEISEN UND GERICHTEN**

**A FULL AND MULTIFUNCTIONAL RANGE TO PRESENT AND SERVE FOOD AND DIFFERENT DISHES**

**UNE LIGNE COMPLETE ET MULTI- FONCTIONELLE POUR PRESENTER ET SERVIR METS ET NOURRITURE EN GENERAL**



**SELF-BREAKFAST:**

**MOLTO DI PIÙ DI UNA LINEA PENSATA PER LA PRIMA COLAZIONE**

---

**VIEL MEHR ALS EINE LINIE GEDACHT NUR FUER DEN FRUEHSTUECKSRAUM**  
**MUCH MORE THAN A RANGE CONCEIVED ONLY FOR THE BREAKFAST-ROOM**  
**BEAUCOUP PLUS QU'UNE LIGNE CONÇUE POUR SERVIR LE PETIT-DEJOURNER**





La linea si compone di elementi refrigeranti, riscaldanti e neutri con relativa vetrina. Self-breakfast è particolarmente versatile poiché:

- può essere utilizzato nella sala riservata alla prima colazione;
- può essere utilizzato nella sala ristorante per esposizione di cibi e bevande;
- utilizzando più elementi accostati funge da linea di self-service quando quest'ultima funzione riveste carattere occasionale;
- si integra con successo con l'arredamento esistente.

Die Palette setzt sich aus Kuehl, Warm, Neutralelementen und der passenden Vitrine (Struktur hiervon) zusammen. Self-breakfast findet eine vielseitige Anwendung:

- Im fruestuecksraum;
- Im Speisesaal zur Ausstellung und Bedienung von Speisen und Gerichten aller Art;
- Als eine Selbstbedienungslinie ueberall dort, wo diese funktion nur gelegentlich gebraucht wird;
- Beste Anpassungsfaehigkeit an den existierenden Einrichtungsstil.

The range consists of cold, warm, and neutral elements together with the relevant glass-structure. Self-breakfast is particularly versatile in that:

- it can be used as a servery by joining more than one element together in all those establishments where the self-service function is only occasionally needed;
- it can be best matched with existing furniture and décor;
- it can be used in the breakfast-room;
- it can be used to display and serve food and different dishes in restaurants.

La ligne est composée par des éléments chauds, froids, neutres avec leur structure vitrée. Self-breakfast s'adapte bien à beaucoup de situations:

- utilisé dans l'espace réservé au petit-déjeuner;
- pour présenter et servir de la nourriture dans un restaurant;
- avec la fonction de libre service en utilisant les divers éléments dans tous les cas où cette fonction n'est que occasionnelle;
- parfaite intégration esthétique avec n'importe quel environnement de travail.

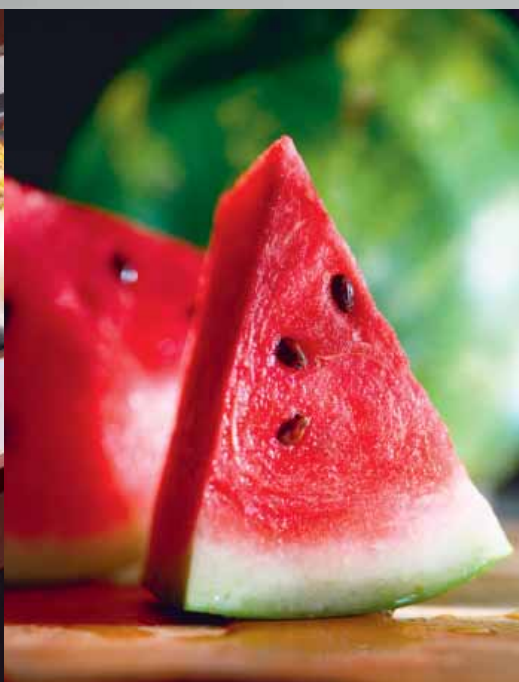

# La gamma - Die Palette - The range - La ligne

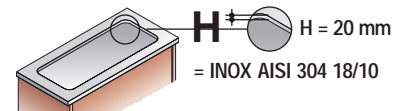
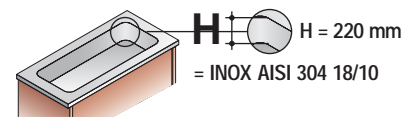
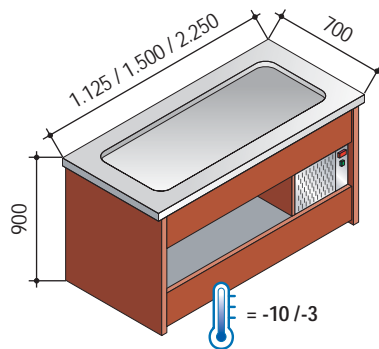
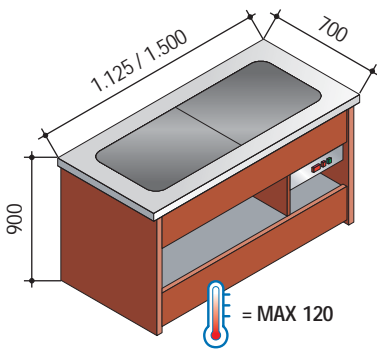
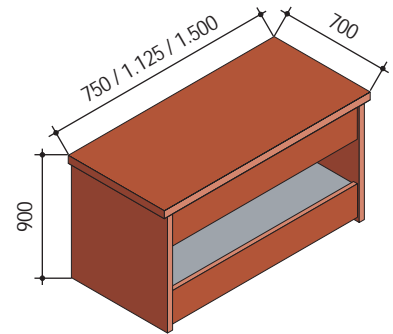
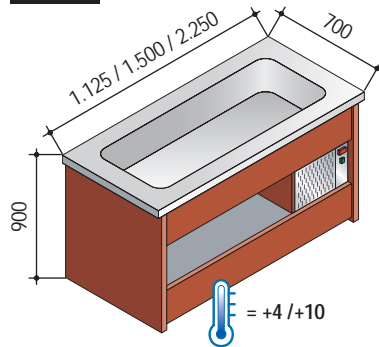
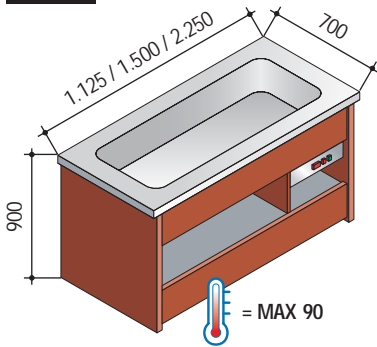

**GAS** = R404A

# Gli accessori - Das Zubehör - The accessories - Les accessoires

